

Stair Light Controller

ES-D(WT)

Dual PIR Sensor + Dual Push Button SPI Controller

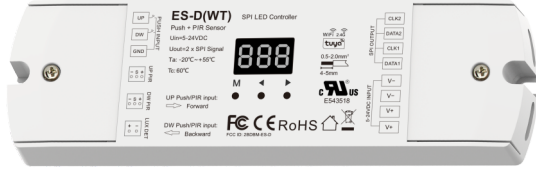

Notice:
Please use in a dry environment
This control circuit is not isolated-see installation instructions
Remarque: Ce circuit de commande n'est pas isolé - voir les instructions d'installation



Features

- Dual PIR sensor + dual push button input RGB or white light SPI controller features daylight sensor.
- Tuya smart APP cloud control and voice control, support for Amazon Alexa, Google Assistant, Tmall Genie and Xiaodu smart speakers.
- Two groups same SPI(TTL) signal output, drive 28 kinds IC digital RGB or white LED strip, IC type and R/G/B order can be set. Compatible ICs: TM1804, TM1809, TM1812, UCS1903, UCS1909, UCS1912, UCS2903, UCS2909, UCS2912, WS2811, WS2812, TM1829, TM1914A, GW6205, GS8206, GS8208, LPD6803, LPD1101, D705, UCS6909, UCS6912, LPD8803, LPD8806, WS2801, WS2803, P9813, SK9822, SM16703P.
- When applied to stair light, supports four output modes: color flow, white flow, color step, white step.
- Sequential switching control is realized when multiple SPI controllers are connected to a single self-resetting push switch button.
- Multiple light colors and change types are selectable with adjustable speed and brightness.
- APP painted segment color mixing: full color filling, color pencil segment painting, eraser segment light off.
- APP custom rich dynamic effects: 44 default and 10+ custom dynamic scenarios, 16 variations.
- 3 APP music rhythms.
- Match with RF 2.4G remote control optional.

Technical Parameters

Input and Output		Sensor Data		Safety and EMC	
Input voltage	5-24VDC	Sensitive field	≤3m	EMC standard	EN IEC 55015/ EN IEC 61547 ETSI EN 301 489-1/-3/-17
Input current	10A	Sensitivity angle	30°(±10°)	Safety standard	EN 60669-1/-2
Output signal	2 X SPI(TTL)			Radio Equipment	ETSI EN 300 440 ETSI EN 300 328
Pixel number	Max 960			Certification	CE RoHS FCC UL
Input signal	PIR sensor + Push button + WiFi + RF 2.4GHz	Environment		Package	
		Operation temperature	Ta: -20°C ~ +55°C	Size	L175 x W120 x H35mm
		Case temperature (Max.)	Tc: +60°C	Gross weight	0.27kg
Warranty		IP rating	IP20		
Warranty	5 years				

Mechanical Structures and Installations

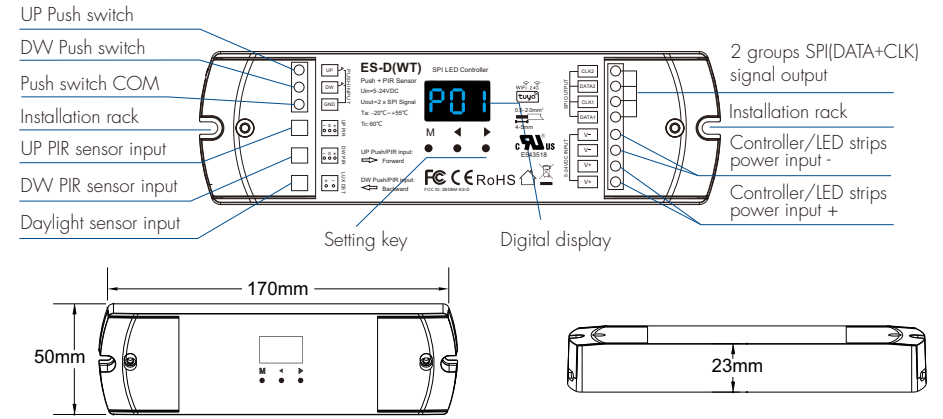

System Wiring

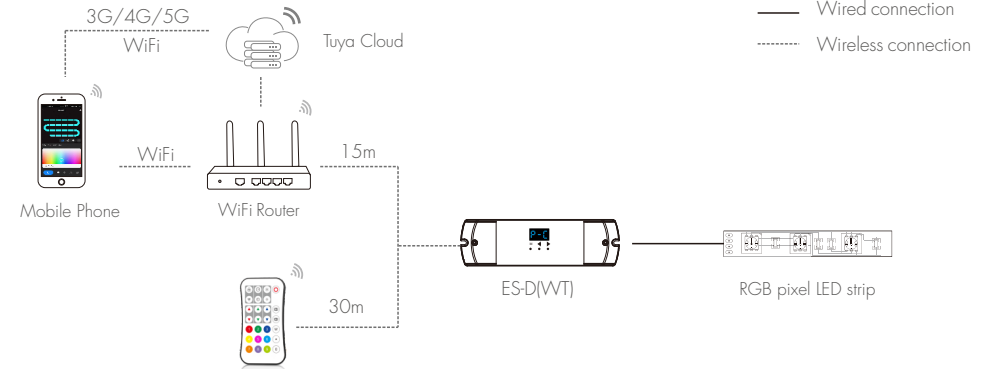

Note:

1. The above distance is measured in spacious (no obstacle) environment, Please refer to the actual test distance before installation.
2. Please check if the WiFi router net in 2.4G band, the 5G band is not available, and do not hide your router network.
3. Please keep the distance between ES-D(WT) devices and router close, and check the WiFi signals.
4. WiFi signal strength detection: open the main interface of social security, click enter the device interface, click "check device network" for testing.

Wiring Diagram

1. Stair light application, connect with PIR sensor, color or white light flow control

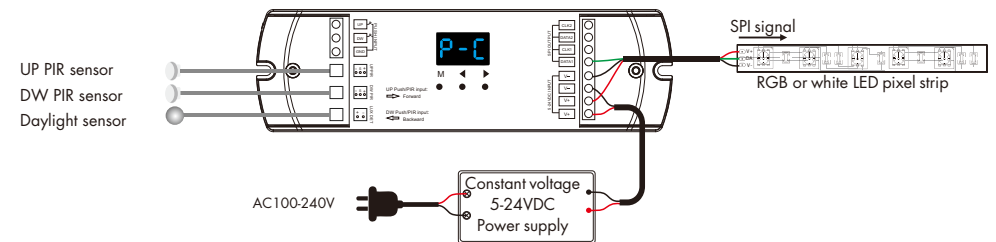

2. Stair light application, connect with PIR sensor, color or white light step control

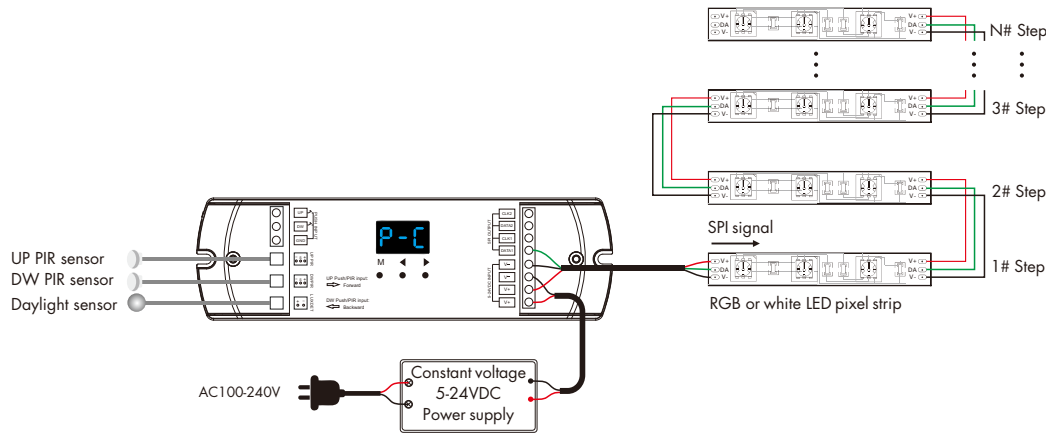

3. One push switch connect with multiple controllers for sequential switching control

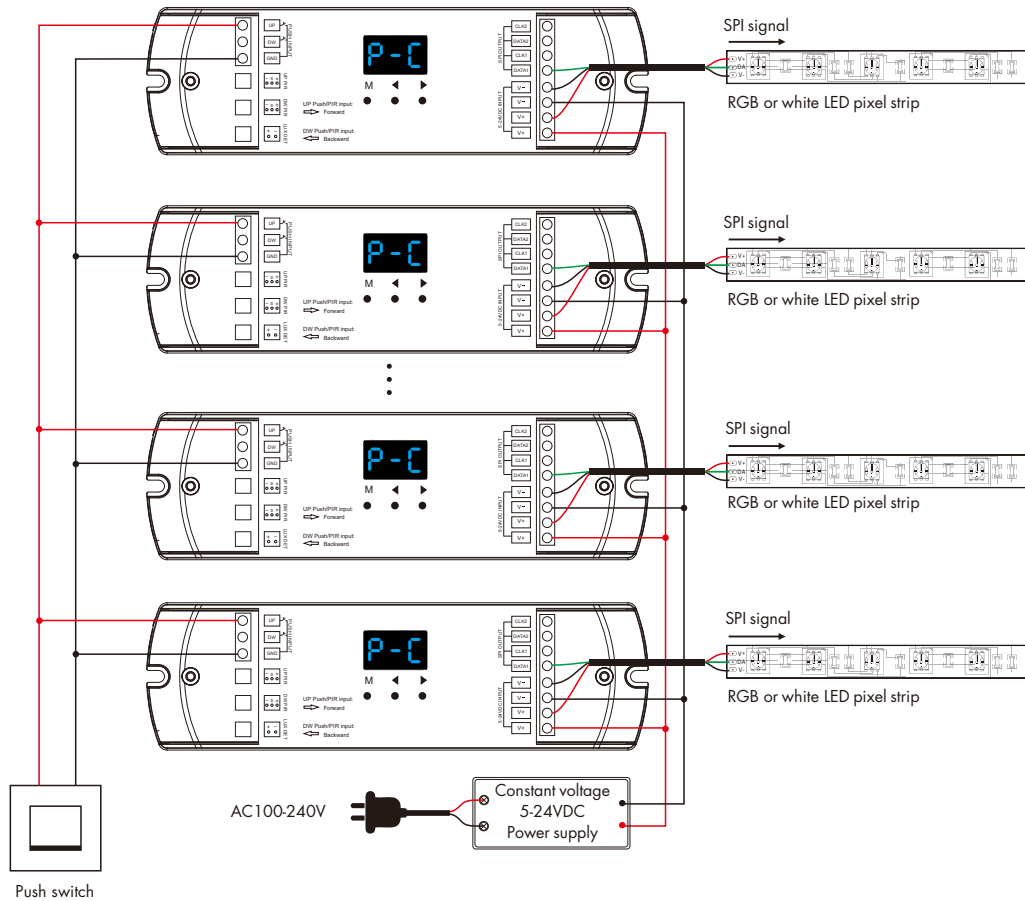

Note:

- If the SPI LED strip is a single-wire control method, the DATA and CLK signal line outputs of the controller are same, and one controller can connect four LED strips.
- If the SPI LED strip is a dual wire control method, one controller can connect two LED strips.
- When the SPI strip load does not exceed 10A, the same power supply can simultaneously power the ES-D controller and the SPI strip at the same time. When the load on the SPI strip exceeds 10A, separate power supplies are required for the ES-D controller and the SPI strip. Only DATA and GND signal lines are connected between ES-D controller and SPI strip.
- The PIR sensor can be replaced with a stair infrared reflection sensor(ES-T) or other sensors that output 5V level signals.
- The color or white light flow model can control up to 960 pixel points of SPI strip.
- The color or white light step model defaults to 30 steps with 10 pixels per step. the step number x pixel length per step must ≤ 960 .

Parameters Setting

1. Light parameter setting

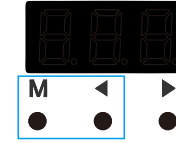

Long press the M and ◀ key for 2s simultaneously, enter the light parameters setting state: set the light type, LED strip connection mode (flow or step) pixel length, step number, light on/off mode, sensor turn off light delay time, daylight detection, self-reset push switch turn on or off light delay time. Short press the M key to switch between parameter settings. Long press the M key for 2s or wait for 1.5s, quit the parameter setting state.

(1) Light type setting



Short press ◀ or ▶ key to switch light type.

3-bead white light: 1 pixel with 3 same data, control 3-bead white LED, display "L-1".

1-bead white light: 1 pixel with 1 data, control 1-bead white LED, display "L-2".

RGB color light: 1 pixel with 3 data, control one R/G/B LED, display "L-3".

Short press M key

(2) LED strip connection mode setting



Short press ◀ or ▶ key to switch LED strip connection mode.

Flow mode: Straight line digital pixel LED strip connection mode, display "o-L".

Step mode: Z-shape digital pixel LED strip connection mode, display "o-S".

Short press M key

Short press M key

(3) Pixel length, step number and step pixel lengths setting

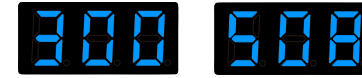

For color or white flow mode, short press ◀ or ▶ key to set the pixel length. The range is 032-960, display "032"-960".

Short press M key

Short press M key

For color or white step mode, short press ◀ or ▶ key to set the step number. The range is 8-99, display "S08"-S99".

For color or white step mode, short press ◀ or ▶ key to set the pixel length of each step. The range is 2-99, display "L02"-L99".

Note: The step number x pixel length of each step number must ≤ 960 .

Short press M key

(4) Light on/off mode setting



Short press M key



Short press M key

i.e., set the sensor activated and self-reset button to turn on or off the light mode (Table 1)
 Short press ◀ or ▶ key to switch two light on mode:
 Sequential light on: Light turn on sequentially from the beginning to the end, display "onS".
 Synchronized light on: Light turn on synchronously, display "onC".

Short press ◀ or ▶ key to switch three light off mode:
 Sequential light off: Light turn off sequentially from the beginning to the end, display "oFS".
 Sequence light off in reverse: Light turn off sequentially from end to beginning, display "oFb".
 Synchronized light off: Light turn off synchronously, display "oFC".

List of ways to turn on/off light combinations:

Display	Name
onS + oFS	Sequential light on, sequential light off
onS + oFb	Sequential light on, sequential reverse light off
onS + oFC	Sequential light on, synchronized light off
onC + oFS	Synchronized light on, sequential light off
onC + oFb	Synchronized light on, sequential reverse light off
onC + oFC	Synchronized light on, synchronized light off

(Table 1)

(5) Sensor delay off time setting



Short press M key

Short press ◀ or ▶ key to switch 10 levels delay time.
 5sec (d05), 10sec (d10), 30sec (d30), 1min (01d), 3min (03d),
 5min (05d), 10min (10d), 30min (30d), 60min (60d), cancel (d00),
 set cancel means not turn off the light.

(6) Daylight detection setting



Short press M key

Short press ◀ or ▶ key to switch 6 levels daylight detection.
 Set the light sensing detection threshold (6 levels):
 10Lux (Lu1), 30Lux (Lu2), 50Lux (Lu3), 100Lux (Lu4), 150Lux (Lu5), 200Lux (Lu6), Off (LoF).
 Factory default light sensing detection is Off (LoF).
 When light sense detection is on, PIR sense turns on the light only
 when the ambient light is lower than threshold value.

(7) Self-reset push switch turn on or off light delay time setting



Short press M key

Short press ◀ or ▶ key to set the self-reset push switch turn on light delay time.
 Setting range 0-15.5s, the smallest unit 0.5s,
 display "o00"~"o95"~"oF5", A-F indicates that 10-15s.
 Setting 0s means turn on light immediately.



Short press ◀ or ▶ key to set the self-reset push switch turn off light delay time.
 Setting range 0-15.5s, the smallest unit 0.5s,
 display "c00"~"c95"~"cF5", A-F indicates that 10-15s.
 Setting 0s means turn off light immediately.

2. LED strip parameter setting



(1) Chip type setting



(2) RGB color order setting



Long press the M and ▶ key for 2s simultaneously,
 enter the LED strip parameters setting state: set the chip type, RGB color order.
 Short press the M key to switch between parameter settings.
 Long press the M key for 2s or wait for 1.5s, quit the parameter setting state.

Short press ◀ or ▶ key to switch chip type (Table 2).

Short press ◀ or ▶ key to switch R/G/B order (Table 3).

LED strip IC types list:

No.	IC type	Compatible IC type	Output signal
C11	TM1809	TM1804, TM1812, UCS1903, UCS1909, UCS1912, UCS2903, UCS2909, UCS2912, WS2811, WS2812, SM16703P	DATA
C12	TM1829		DATA
C13	TM1914A		DATA
C14	GW6205		DATA
C15	GS8206	GS8208	DATA
C21	LPD6803	LPD1101, D705, UCS6909, UCS6912	DATA, CLK
C22	LPD8803	LPD8806	DATA, CLK
C23	WS2801	WS2803	DATA, CLK
C24	P9813		DATA, CLK
C25	SK9822		DATA, CLK

(Table 2)

LED strip RGB color order:

R/G/B order	RGB	RBG	GRB	GBR	BRG	BGR
Digital display	0-1	0-2	0-3	0-4	0-5	0-6

(Table 3)

Light Effect Settings by Key

(1) Light color setting

Short press ◀ key to switch 16 color light in sequence (Table 4).



Color Flow/Color Step mode, the digit shows P01~P95.

White Flow/White Step mode, the digit shows P-1~P-5.

Color light type (2nd digit):

NO.	Name	NO.	Name
0	Rxxx Gxxx Bxxx (User define)	8	R/G/B 3 color
1	Red	9	7 color
2	Orange	A	Red + yellow
3	Yellow	b	Red + purple
4	Green	c	Green + yellow
5	Cyan	d	Green + cyan
6	Blue	E	Blue + cyan
7	Purple	F	Blue + purple

(Table 4)



Light color type
(RGB / custom)

(2) Light change type setting

Short press ▶ key to switch 5 light change types in sequence (Table 5).

Color/white light change type (3rd digit):

NO.	Name
1	Flow
2	Chase
3	Float
4	Trail
5	Trail+black section

(Table 5)



Light change type
(Flow)

(3) Speed, brightness, self-defined color setting

Short press M key to switch three parameter items;

Short press ◀ or ▶ key to adjust the value of each parameter item.

Speed, brightness, and self-defined R/G/B color parameter value description:

Speed: 1-8 levels adjustable, display "S-1"-"S-8", S-8 is the maximum speed.

Brightness: 1-10 level adjustable, display "b10"-"bFF",

bFF means maximum brightness 100%.

Self-defined R/G/B color: 0-255 (00-FF) adjustable.

R channel displays "100"-"1FF"; G channel displays "200"-"2FF";

B channel displays "300"-"3FF".

Long press the M key for 2s or wait for 15s,

quit the light effect parameter setting state.



Speed(8 level)



Brightness(100%)



R channel brightness(100%)

Note:

1. White flow / white step mode does not support self-defined R/G/B color function.
2. For color flow / color step mode, the light color and light change type are combined to form 50 kinds of light effects.
3. For color flow / color step / white flow / white step mode, can be adjusted in speed and brightness.

Match RF Remote Control

Long press M, ◀ and ▶ key for 2s simultaneously, the digital display "RLS", enter remote control matching status, immediately press on/off key (single zone remote) or zone key (multiple zone remote) of the remote, display "RLO" means successful match.

When the light is turned off using the remote control, digital display "OFF".

Factory Default Parameter Setting

- Long press ◀ and ▶ key for 2s simultaneously, restore factory default parameters, display "RES".
- Factory default parameters: Clear all matched remote control, RGB color light flow output, 300 pixels, sequential light on, sequential light off, 30s delay off time, disable daylight detection, push switch turn on delay and turn off delay is 0s, chip type TM1809, RGB order.

Tuya Smart APP Network Connection

Long press M, ◀ and ▶ key for 5s simultaneously, clear previous network connection, enter WiFi config mode, the digital tube flashes "-C-".

In Tuya smart APP, you can find ES-WT device. If Tuya smart APP network connection succeed, the digital tube will stop flash.

When controlling the light with Tuya Smart/Smart Life APP, if the network connection is poor, you can control the light with Bluetooth connection within the Bluetooth control range.

Note: The light can not be directly controlled by Bluetooth without WiFi configuration.

Tuya Smart APP Interface

LED strip length, chip type and color sequence can be set either through the controller buttons or through the Tuya smart APP interface.

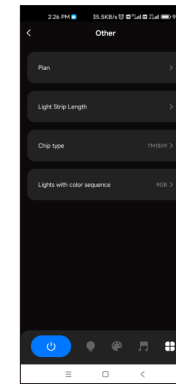

Other interface

For the first time use, set LED strip length, chip type and color sequence.

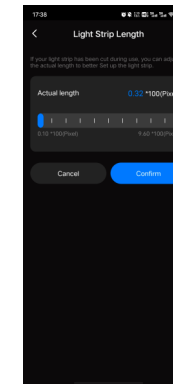

Light Strip Length interface

Strip length setting:
Select the appropriate number of pixels according to the actual length of the strip,
flow output mode: 32-960.
Step output mode: 16-960.

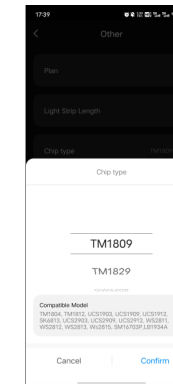

Chip type interface

Select the corresponding chip according to the chip type of the light strip and list of chip types supported by the controller.

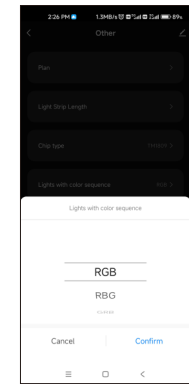

Lights with color sequence interface

Select the corresponding R/G/B sequence according to the color sequence of the light strip. (RGB, RBG, GRB, GBR, BRG, BGR)

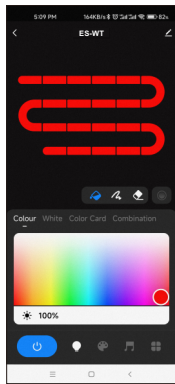

Colour:

Touch the color rectangle to adjust color and saturation. Touch the brightness slide to adjust brightness.

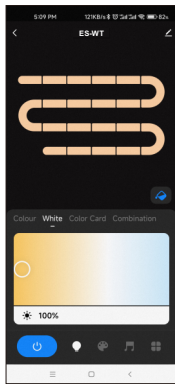

White:

Touch the color rectangle to adjust color temperature. Touch the brightness slide to adjust brightness.

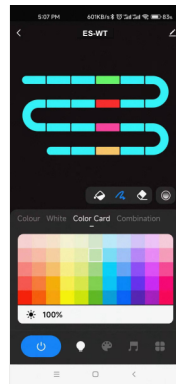

Color Card:

Touch the color card array to select many different colors. Touch the brightness slide to adjust brightness.

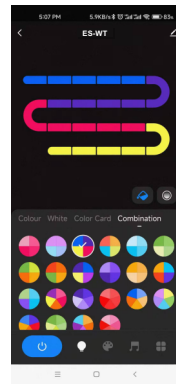

Combination:

Select a proportional distribution of multi-color circle, evenly distribute these colors on the LED strip.



Color Fill:

Change the color of the full segment of the LED strip.



Color pen:

change the color of a single segment of the LED strip.



Eraser:

Erase the color of a single segment of the LED strip, i.e., turn off the light.



Color transition:

When there are multiple colors in the LED strip, you can set to turn on or off the color segment gradient transition.

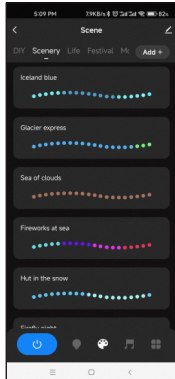

Scene interface

44 predefined scenarios and 10+ custom dynamic scenarios selectable. The custom scenarios can select 16 types variations (fade, jump, breath, flash, flow, rainbow, shooting star, pile-up, floating down, chasing light, floating, flashing, bouncing, shuttle, chaotic flashing, open and close), the 1-8 colors, full or segment direction, forward or reverse motion direction, adjustable brightness and speed.

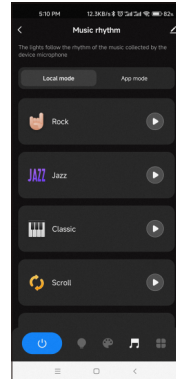
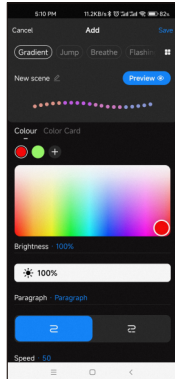

Music rhythm interface

6 local music modes (rock, jazz, classical, rolling, energy, spectrum) selectable. 3 APP modes (music rhythm, game, romance) selectable. Adjustable sensitivity of the received sound. The light follows the rhythm according to the music collected by the phone microphone. Note: the controller only supports App mode.

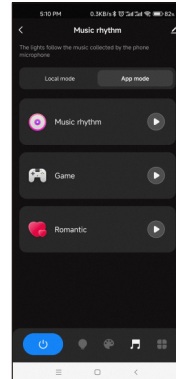

Notes.

- In APP, a light strip is fixed with 20 segments, Strip length (total number of pixel points) ÷ 20 segments = number of pixel points per segment.
- The maximum length of the light strip is 960 pixels, for example, a light strip of 5 meters long with 60 pixels per meter, you can set the length to 300 pixels. The whole light strip is divided into 20 segments, each segment has 15 pixels.
- When the light strip length is less than or equal to 20 pixels, for example, 10-20, each pixel sequentially corresponds to each segment from the beginning.
- When the light strip length is not an integer multiple of 20, the remainder of the strip will display the color of the last segment.
- When the actual light strip length is not an integer multiple of 20, it is recommended to set the length longer and increase the value to a multiple of 20.
- When the set of the light strip length is less than the actual length, the back part of the light strip can not be controlled.
- When the selected dynamic mode cycle running interval is too long, please reset the correct pixel length.
- When the static or dynamic mode color display is not consistent with the APP interface, please re-select the light strip color sequence.

Typical Application

1. Dual PIR sensing

- Connect two PIR sensors to realize automatic staircase light control.
- The UP PIR sensor is installed at the bottom of the staircase, when sensing a person, the digital tube instantly displays "-u-", the light is automatically turned on, and the light is turned off with a delay.
- The DW PIR sensor is installed at the top of the staircase, when sensing a person, the digital tube instantly displays "-d-", the light is automatically turned on, and the light is turned off with a delay.
- If you set the daylight sensor detection on, the light will be turned on only in darker environment or at night.

2. Dual self-reset push switch control

- Connect two push switches for manual control of stair lights. The UP push switch is installed at the bottom of the stairs; the DWV push switch is installed at the top of the stairs.
- Set the self-reset push switch to 0s for both light on delay and light off delay. Short press the self-reset push switch to turn on the light, display the current light effect mode; short press the self-reset push switch again, turn off the light, display "OFF". Long press the UP self-reset push switch to adjust the brightness, range 10-100%, digital tube display "b10""bFF". Note: The DWV self-reset push switch does not have the function of adjusting the brightness.
- Using self-reset push switch control will ignore the daylight sense detection.

3. Self-reset switch connects multiple controllers for sequential switching control

- Multiple controllers are connected to one or two push switches at the same time to realize sequential switching control.
- Set the self-reset push switch light on/off delay time of multiple controllers to incremental or decremental values, for example: set 1-4# controllers' push switch light on delay time to 0s, 1s, 2s, 3s respectively, and push switch light off delay time to 3s, 2s, 1s, 0s respectively. In this way, 1-4# controllers will turn on the lights in the same order, and turn off the lights in the reverse order.
- Short press the self-reset push switch to turn on the lights sequentially. during the delayed light on time, digital display "don". When the light on, display the current light dynamic mode.
- Short press the self-reset push switch again to turn off the lights sequentially. during the delayed light off time, digital display "doF". When the lights off, digital display "OFF".

Note:

- When the lighting effects of multiple controllers are confused, it can be quickly restored by double-click the self-reset push switch.
- Using the self-reset switch to control multiple controllers will ignore the sensor delay off time and daylight detection settings.

Installation of PIR Sensor

Size of detector:

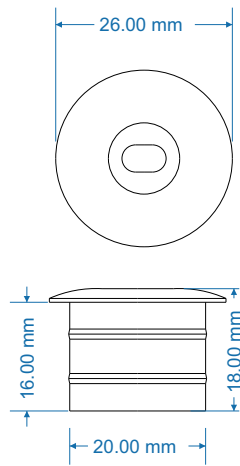

PIR sensor detection scope ($\pm 10^\circ$ Error):

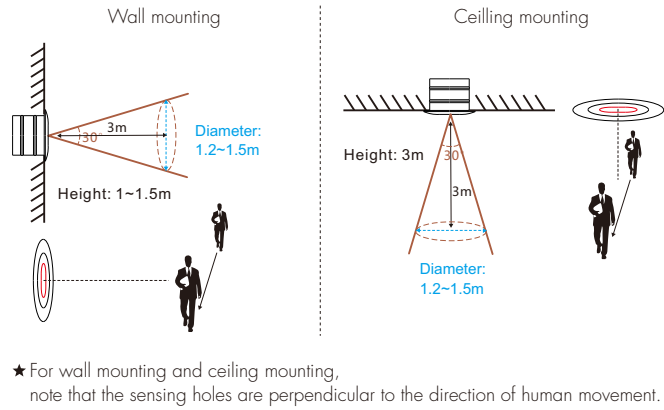

Notice for installation of PIR sensor

1. Recommended for wall mounting.
2. If the sensor is exposed to direct sunlight, interference signal will be introduced.
3. The sensor should be installed in a dry environment and keep away from windows, air conditioner and fans.
4. Make sure that the sensor stays away from heat source, such as countertops, kitchen appliances which generate hot steam, walls and windows in direct sunlight, air conditioner, heating, refrigerators, stoves and so on.
5. We recommended the wall-mounted installation height is 1-1.5 meters and the ceiling mounting height is no more than 3 meters.
6. There should not be shelter(screen, furniture, large bonsai) within the range of detection.

Tc Point Location

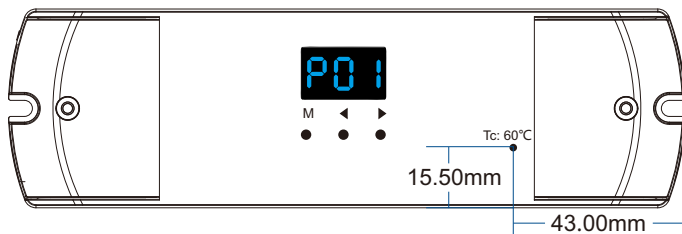

The Tc point is located on the front of the controller.

Statement

FCC ID Statement:

Mobile

RF Exposure Information

This equipment complies with FCC radiation exposure limits set forth for an uncontrolled environment.

This equipment should be installed and operated with minimum distance 20cm between the radiator and your body.

Packing List

